

Installation Instructions

*Residential Reverse Osmosis
Drinking Water System*

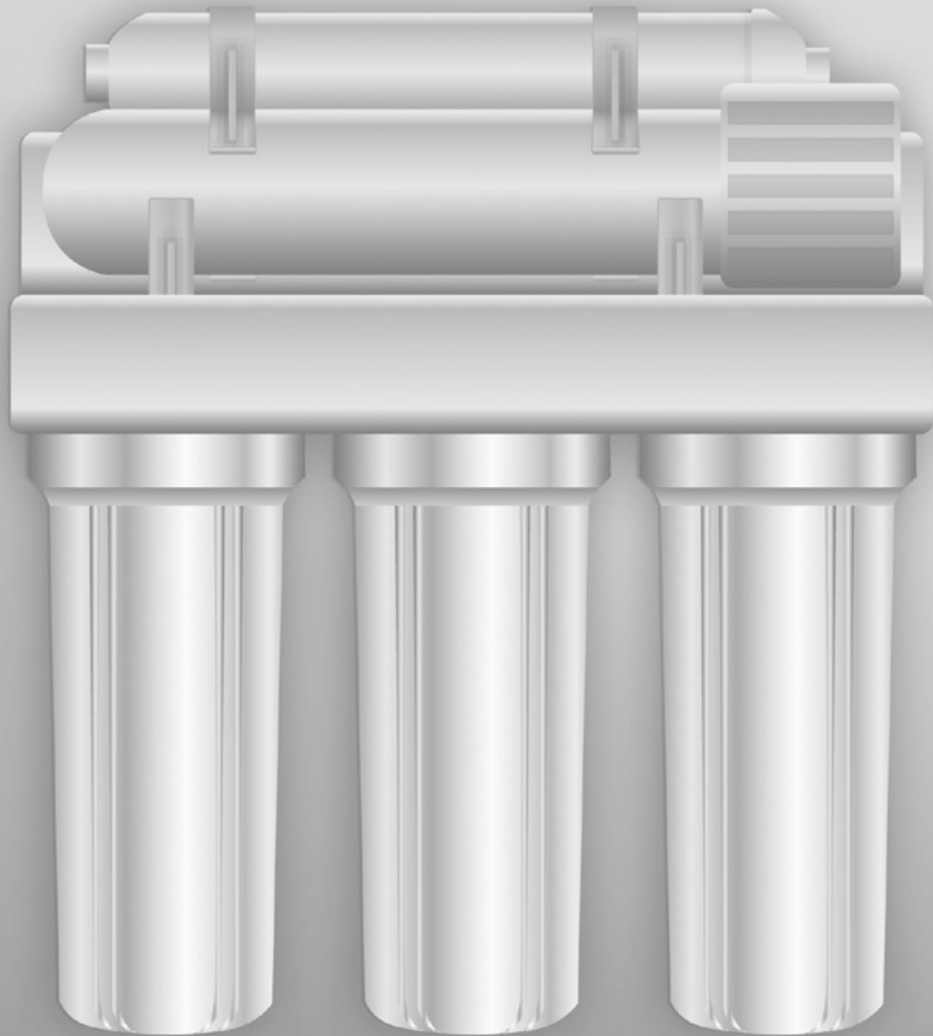

FIVE STAGE

TABLE OF CONTENT

I. COMPONENTS AND TOOLS IDENTIFICATION	3
II. PRE-INSTALLATION	3
System Location	4
Site Preparation	4
Unit Preparation	4
III. INSTALLATION INSTRUCTIONS	4
Faucet Installation	4
Feed Water Adapter Installation	5
Drain Saddle Installation	6
Initial Tubing Connections	7
RO Component Installation	7
RO Unit Installation	7
Pre-fill Storage Tank and Placement	7
Final Tubing Connections	7
IV. SYSTEM START-UP	7
Pre-Start Instructions	7
Flushing and Operation Check	7
V. MAINTENANCE	8
Sanitizing Instructions	8
Water Quality	9
Water Production	9
Water Pressure and Temperature	9
VI. FITTINGS INSTALLATION INSTRUCTIONS	10
Quick Connect Fittings	10
Conventional Compression Fittings	10
VII. FLOW CHART & SPARE PARTS	11
VIII. FILTER REPLACEMENT INSTRUCTIONS	12
IX. WARNINGS	12
X. WARRANTY	12



WARNING: READ ENTIRE MANUAL. FAILURE TO FOLLOW ALL GUIDES AND RULES COULD CAUSE PERSONAL INJURY OR PROPERTY DAMAGE.



CHECK WITH YOUR STATE AND/OR LOCAL PUBLIC WORKS DEPARTMENT FOR PLUMBING CODES.



WARNING: DO NOT USE WITH WATER THAT IS MICROBIOLOGICALLY UNSAFE OR OF UNKNOWN QUALITY WITHOUT ADEQUATE DISINFECTION BEFORE OR AFTER THE SYSTEM.

NOTE: Failure to comply with these installation instructions will void the product Warranty, and the installer will be responsible for any service, repair or damages caused thereby.

I. COMPONENTS AND TOOLS IDENTIFICATION

Your Reverse Osmosis System has been tested to ensure it will operate correctly. The following periodic maintenance is recommended so your system will provide years of trouble-free service:

Replacement part	Frequency
Pre-filter (sediment)	Every 6 mos.
Pre-filters (activated carbon)	Every 6 mos.
R/O membrane	Every 2-3 years
Post filter (carbon)	Every 6 mos.

Components

The following components make up your Reverse Osmosis Drinking Water System:

PRE-FILTER (sediment) removes larger particles such as sand, silt, rust and scale.

PRE-FILTERS (activated carbon) remove chlorine in the feed water to protect the reverse osmosis membrane.

REVERSE OSMOSIS MEMBRANE reduces *dissolved* minerals, metals and salts. During the process, harmful compounds are separated by the membrane and the reject water goes to waste (drain).

An activated carbon **POST-FILTER** is provided for a final "polish" and to remove foul tastes, odors and to provide great tasting drinking water.

FILTER HOUSINGS and **R/O MODULE** hold pre-filters and membranes. A **BRACKET** is provided so they may be mounted, typically below sink.

STORAGE TANK holds filtered water, ready for use.

AUTOMATIC SHUT-OFF VALVE senses when the storage tank is full and closes the water supply to conserve water.

The dedicated **FAUCET** is used to dispense RO produced water when needed.

FEED WATER VALVE is connected to the cold water line to supply water to the R/O system.

WASTE WATER SADDLE VALVE is connected to the drain to remove reject water from the R/O system.

TUBING supplies feed and reject water.

FITTINGS are used for necessary hose connections.

Tools

The following tools may be necessary, depending on each particular installation:

- 3/8" variable speed electric drill, 1/8" & 1/2" bits
- 1-1/4" porcelain hole cutter (if hole for second faucet is not provided)
- Center punch and hammer
- 1-1/4" wood bit
- Concrete drill bits
- Phillips head and flat blade screwdrivers
- Adjustable wrench
- Crescent wrench
- Teflon tape
- Plastic tube cutter
- Air pressure gauge (low pressure)
- Air pump (hand)

II. PRE-INSTALLATION

System Location

Your R/O system may be installed under a sink, in a basement or other location, depending on available space. Do not install unit where temperatures fall below freezing; otherwise, damage will result. Connection to an icemaker should also be considered for optimum performance.

Guidelines for component placement are as follows:

FAUCET should be placed near the sink where drinking/cooking water is normally required. A 2" flat surface is required to mount the faucet if an existing hole for a second faucet is not available. The thickness of the mounting thickness should not exceed 1-1/4".

STORAGE TANK may be placed where it is convenient, within ten feet of the faucet. Under the sink or in a nearby cabinet are excellent choices. If tank is located further than 10 feet from the faucet, use 1/2" tubing to reduce pressure drop. Full tanks may weigh more than thirty pounds, so a sturdy shelf is required.

Installation Instructions

Residential Reverse Osmosis Drinking Water System

R/O UNIT may be mounted on either side of the sink, in a cabinet or heated basement, with nearby access to a potable, cold water line.

FEED WATER CONNECTION is accomplished with a feed water valve. Locate this assembly as close to the R/O unit as possible. Connect to a potable, cold water supply line only.

NOTE: *Softened water is preferred since it will extend the life of your R/O membrane.*

DRAIN CONNECTION is accomplished using a waste water saddle valve which is designed to fit around a standard 1-1/2" OD drain pipe. The drain saddle valve should always be installed above (before) the tap and on the vertical or horizontal tailpiece.

Do not install the drain saddle valve near a garbage disposal; otherwise, plugging of the waste water line may occur. If discharging into a utility sink or standpipe, an air gap must be provided. (Air gaps must be 1" or greater above the floor rim.)

NOTE: *Plumbing codes may require the use airgaps. Please check with your local municipality.*

Do not connect the R/O system drain line to the dishwasher drain line due to the fact back pressures may cause the air gap to overflow.

Site Preparation

Installing dealers may want to speak with customers in advance and ask them to clean under the sink to save time. If a basement installation is advisable, check area to determine if extra fittings or hosing are required. Upon arrival, it is a good idea to check the condition of all plumbing for potential leaks and advise customer so there will be no misunderstandings in the event leaks occur.

Unit Preparation

Open shipping carton, remove components and check that all parts are present. Check empty storage tank to be sure air pressure is approximately 7 PSI.

NOTE: *Adjust if necessary.*

III. INSTALLATION INSTRUCTIONS

NOTE: All plumbing must be completed in accordance with state and local plumbing codes. Some municipalities may require installation by a licensed plumber. Check local authority prior to installation.

STEP 1. Faucet Installation

If the sink has a sprayer it may be disconnected for faucet installation. (Installing dealers should discuss this with customers.) A pipe cap or plug will be necessary to seal the sprayer connection.

To make the faucet mounting hole (if sprayer or second hole is not used), check below to make sure the drill does not interfere with anything below. Center punch a small indent at the desired faucet location. (2" flat surface is required, not exceeding the chassis punch and tighten nut to cut the desired hole size. Clean up sharp edges.

The faucet should be positioned so it empties into the sink and the spout swivels freely for convenience. If sink has a hole that can accommodate the RO faucet, no drilling is required.

Proceed with mounting the faucet.

⚠️ PORCELAIN, ENAMEL, CERAMIC ON METAL OR CAST IRON PRECAUTIONS MUST BE TAKEN TO PENETRATE THE PORCELAIN THROUGH TO THE METAL BASE AND PREVENT IT FROM CHIPPING OR SCRATCHING.

Tools required:

- Variable speed drill
- Relton porcelain cutter tool set (7/8" or alternative size, 9/16")
- Plumber's putty

Procedures

1. Mark the center for the 7/8" hole.
2. Form shallow putty around hole area and fill with enough water to lubricate carbide drill bit.
3. Carefully drill pilot hole through all layers. (Use light pressure and slow speed.)
4. Insert pilot tip of spring-loaded porcelain cutter into pilot hole.

Installation Instructions

Residential Reverse Osmosis Drinking Water System

5. Drill porcelain/enamel using spring loaded porcelain cutter, making certain a complete ring has been cut through the porcelain / enamel to the metal base.
6. Cut away the inner porcelain / enamel disc down to the base metal. Make certain the cutter does not touch outer rim of the cut porcelain / enamel. Continue with his bit to cut through metal until sink has been completely penetrated.

NOTE: Always use sharpened porcelain cutter to eliminate chips and cracks.

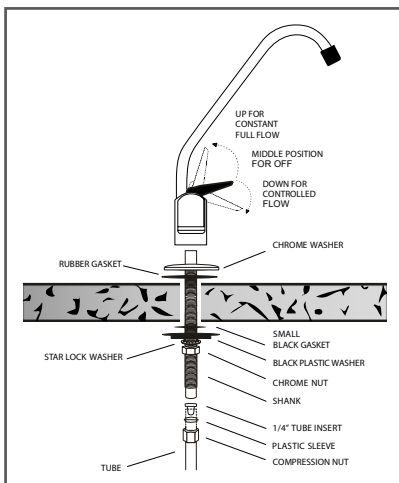

Faucet installation without air gap

Installation Procedures for Stainless Steel Sinks

Recommended tools:

- Center punch
- Variable speed drill
- High speed drill bits
- Greenlee chassis punch 7/8" (or 9/16" for non air gap faucets)
- Protective gloves & eye protectors

Procedures

1. Center punch small indent for hole.
2. Drill the required pilot hole.
3. Set-up the chassis punch per instructions and tighten nut to cut the desired hole size.
4. Clean up sharp edges with file.

Mounting the Faucet

Disassemble hardware from the threaded nipple, except for chrome base plates and rubber washers.

(Rubber washers may be replaced with bead of plumber's putty for neater appearance.)

Feed the threaded nipple through sink or counter mounting hole and orient the faucet. From below sink or counter, assemble the white spacer flat washer and hex nut on threaded nipple and tighten by hand. (Open end up; open side toward air gap). After checking faucet orientation, tighten with a wrench until secure.

STEP 2. Feed Water Adapter Installation

⚠ CAUTION!! For your safety and protection, do not use where water is microbiologically unsafe or of unknown quality. The water supply to your system **MUST** be from the COLD WATER LINE! Hot water will severely damage your reverse osmosis system!

1. Turn off cold water supply to the sink using the supply valve located under the sink.

NOTE: In some cases the supply valve may leak or may not work at all. If this happens turn off the water at the main water shut off for the entire house. In extreme cases the house shut off valve does not work. If this happens shut the water off at the street and replace the defective valves immediately. Locate the type of shut off valve you have under your sink and follow that step for connecting the feed water.

2. Some shut off valves have an extra port for an icemaker hookup. You will not need the feed water adapter for this type of installation. (See diagram A)
3. On some shut off valves you can install the feed water adapter directly to the valve. Tighten feed water adapter to the valve with an adjustable wrench. Tighten until snug. (See diagram B)

⚠ TIGHTEN BY HAND ONLY! DO NOT OVERTIGHTEN!

Most under sink shut off valves have a built in smooth or corrugated riser going up to the faucet. (Refer to diagram C for help with this type of valve)

Installation Instructions

Residential Reverse Osmosis Drinking Water System

Secure an adjustable wrench to the fitting on the cold water side of the sink faucet -- **NOT THE R.O. Faucet!**

Secure another adjustable wrench to the smooth/corrugated riser line nut. Gently undo the riser line from the sink faucet. Do not be alarmed! There will be water left in the line—this is normal. However, if the flow does not stop you probably haven't shut the water off properly.

4. Screw the two supplied 1/2" adapters onto the fitting coming from the cold water side of the sink faucet. Hand tighten the feed water adapter to the cold water line. Take extreme care not to twist or damage the connection to the cold water connection.

⚠ CAUTION!! Tightening the connector improperly to the faucet could cause irreparable damage to the faucet.

5. Connect the riser from the water shut off valve to the feed water adapter. Ensure that the cone washer on the riser tube is in good condition. With one adjustable wrench on the feed water adapter and another adjustable wrench on the riser nut connect the riser to the feed water adapter.

⚠ DO NOT OVERTIGHTEN!
This can cause damage to the riser connection.

6. Insert the 1/4" white tube into feed water adapter.

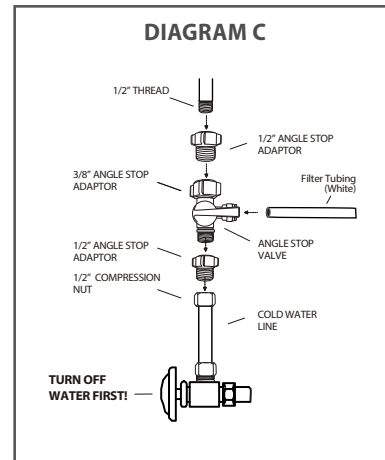
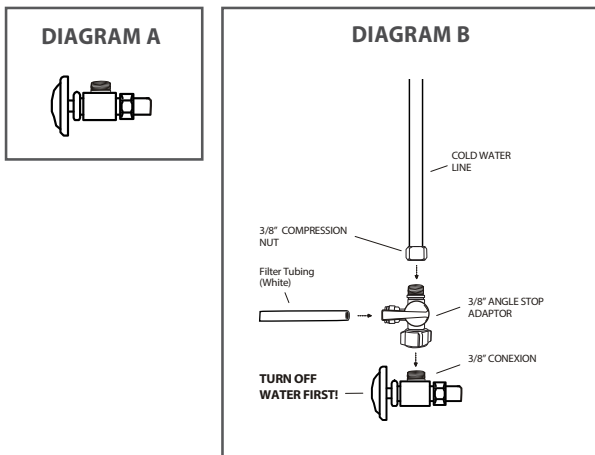

STEP 3. Drain Saddle Valve Installation

Prior to proceeding it is important to inspect the condition of drain pipes to make sure they are not thin and frail.

Drain saddle valves are designed to be installed on standard 1-1/2" OD drain pipe. Install drain saddle valve above (and before) the trap and on the vertical or horizontal tailpiece. Never install a drain saddle valve close to the outlet of a garbage disposal or plugging of the RO drain line may result.

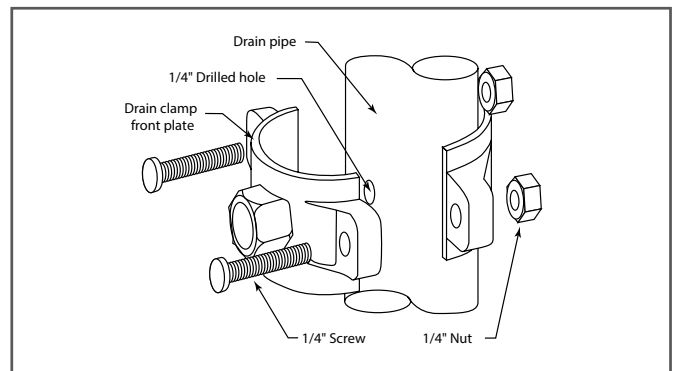

Drain saddle valve installation (brass insert)

Procedures

1. Position threaded half of drain saddle valve at selected location and mark for the opening.
2. Drill 1/4" hole at mark through one side of pipe.
3. Position both halves of drain saddle on drain pipe so threaded opening lines with hole.
4. Secure drain saddle clamp on valve with bolts and nuts provided. (Do not over tighten and make sure there is

equal space between saddle halves on each side.)

STEP 4. Initial Tubing Connections

For convenience on under counter installations it may be advisable to complete under counter hose connections at this time. (*Fittings Installation Instructions on page 10*)

STEP 5. RO Component Installation

Install RO membrane, carbon pre-filter and sediment pre-filter in modules of RO unit. (Refer to RO installation diagram.)

STEP 6. RO Unit Installation

The RO unit is normally mounted to the right or left sink cabinet sidewall, depending on where supply tank is to be located. Generally the unit is installed at the front of the cabinet and the tank at the rear.

To mount the unit, elevate it at least 2" off the floor, level it and mark the location of mounting holes needed. Drill holes for mounting screws and install screws, allowing the mounting bracket slots to slip over them.

NOTE: *If the cabinet sidewalls are not solid, unit may sit on the floor with screws to keep it against the cabinet in a vertical position.*

STEP 7. Pre-fill Storage Tank and Placement

Pre-filling the storage tank is always recommended so there is sufficient pressure to check for leaks and sufficient water to flush the carbon post filter.

It is important to use a sanitizer (such as Clorox) so tubing, fittings, tank and the faucet will be safe to use upon start-up.

To pre-fill storage tank follow these directions:

1. Connect storage tank to feed water line.
2. Open feed water valve and valve on tank.
3. Allow to fill for approximately three minutes.
4. Turn off feed water valve and tank valve.
5. Do not flush tank for approximately 15 minutes.

The supply tank should be placed under the counter or within 10 feet of the RO unit.

NOTE: *Tanks are pre-pressurized at 7 psi. Prior to installation, check, add or release as required.*

STEP 8. Final Tubing Connections

With all components in place, complete final tubing

connections using these guidelines:

- Tubing should follow contour of the cabinets.
- Cut tubing to desired length using square cuts and proper cutting device.
- Make no sharp bends.
- Keep tubing from the RO unit to the tank and faucet as short as practical for good flow.

Under sink installations following installation diagram and the following procedures:

1. Connect tubing from faucet to RO unit.
2. Connect tubing from tank to RO unit.
3. Connect tubing from supply valve to RO unit.
4. Connect tubing from drain valve to RO unit.

(For Fittings Installation Instructions go to page 10)

Icemaker Hookup (optional)

The RO drinking water device can be connected to any standard refrigerator ice maker or ice maker/water dispenser. (Do not connect to a commercial type bar ice maker.)

To complete this operation, connect a tee with shutoff valve into the faucet tubing and route tubing to the refrigerator. (Hooking up to an existing copper line is not recommended unless it is new installation.) Shut off ice maker by lifting lever prior to turning off the existing tap water supply line to the refrigerator. Turn on ice maker after the RO system has been drained several times and the tank has a full supply of water.

NOTE: *Before any service is performed on the RO system, turn off ice maker valve and ice maker unit. Turn back only after RO tank is full.*

IV. SYSTEM START-UP

Pre-Start Instructions

1. Check all connections to be sure they are secure.
2. Turn on feed water valve and check for leaks. (Turn off and correct leaks if leaks occur.)
3. Open valve on storage tank and open faucet until a steady stream of water flows.
4. Close faucet and wait five minutes to see if leaks result.

NOTE: *When the system is first turned on, water may intermittently "spurt" from the air gap opening on the side of air gap faucets. This is common and should correct itself after an initial period of time.*

Flushing and Operation Check

Installation Instructions

Residential Reverse Osmosis Drinking Water System

To make sure RO system is operating correctly, following these simple procedures:

1. Open faucet handle and allow tank to completely drain of sanitizing solution.

⚠ DO NOT USE THIS WATER!

NOTE: *When tank is empty, faucet will steadily drip. This is the rate the RO system processes water.*

2. With faucet handle in "open" position, measure the rate of the steady drip from spout. Use a graduated cylinder and watch with a second hand to calculate approximate production in gallons per day.

NOTE: $\text{Milliliters per minute} \times 0.38 = \text{GPD}$
 $\text{Ounces per minute} \times 11.2 = \text{GPD}$

3. Proceed to check reject flow rate by disconnecting tubing at drain connection and measure flow as described above.

NOTE: *Proper ratio should be 3 reject water to 1 part of product water, on average.*

4. Close faucet and re-inspect system for leaks.
5. Allow system to process water for approximately four hours, at which point tank will be practically full.
6. Open faucet again and allow tank to empty for a second time.

⚠ DO NOT USE THIS WATER!

7. Wait another four hours to allow tank to re-fill.

NOTE: *If no objectionable tastes are noticed after second tank draining, RO processed water is ready for use. Otherwise, drain tank and re-fill for a third time.*

8. At this point supply line to ice maker connection (optional) may be opened.

V. MAINTENANCE

Your RO system contains filters and membranes which must be replaced periodically for proper operation. (Please see page 1 for general changeout recommendations.)

NOTE: *Change-out procedures may be amended, depending on source water conditions.*

To change filters and membranes follow these procedures:

1. Close feed water valve by turning it clockwise.
2. Open faucet to allow holding tank to drain.
3. Loosen and remove filter housings using wrench provided and discard cartridges and or membrane.
4. Wash the inside of the housings using mild

detergent and soft cloth.

Thoroughly rinse all soap before reassembly.

5. Replace filter cartridges and membrane before sanitizing system.

NOTE: *The system should be sanitized before installing the activated carbon post filter cartridge.*

Sanitizing Instructions

To sanitize system follow these procedures with the feed water valve closed:

Remove pre-filters and membrane from housings.

1. Use 5-1/4% unscented bleach such as Clorox.
2. Add one cap full (2 tsp or 10 ml) of bleach to each pre-filter housing and membrane module.
3. Carefully re-fill housings with tap water and temporarily replace **WITHOUT** carbon cartridge, sediment cartridge or membrane installed.
4. Slowly open the feed water line at faucet.
5. Close faucet as soon as water begins to drip out of spout.
6. Let system stand for approximately 15 minutes.
7. After fifteen minutes do the following in order:
 - Close feed water valve.
 - Close holding tank valve while faucet is open to release pressure.
8. Remove housings and empty them.
9. Remove any protective wrap from pre-filters and membrane and install them in the appropriate filter housings. Tighten with wrench.
10. Replace post carbon filter if necessary.

NOTE: *Be sure to check o-rings are in place when installing cartridges in filter housings.*

11. Disconnect product water tubing from the holding tank and put 50 drops of bleach into the tubing. Reconnect tubing.
12. Slowly open feed water saddle valve. When water begins to drip from faucet, close faucet and open holding tank valve.
13. Do not open faucet for at least eight (8) hours.
14. Discard the first two tanks of water produced, as they contain chlorine.

15. ⚠ DO NOT USE THIS WATER!

16. When faucet is first opened, air and black carbon powder may be noticed. This is normal.

Water Quality

Water quality from an RO system is normally determined with a TDS Meter, which measures total dissolved solids in water, measuring conductivity. The results are normally measured in parts per million or milligrams per liter. Fewer dissolved solids results in higher quality water.

RO membranes are rated by the amount of dissolved solids they reject expressed as “rejection percentage”.

For example:

If feed water contains 100 ppm of dissolved solids and the product water after the membrane has 10 ppm of dissolved solids the rejection rate is 90%.

The formula is as follows:

$$\text{Percent Rejection} = \frac{(\text{Feed H}_2\text{O TDS} - \text{Product H}_2\text{O TDS}) \times 100\%}{\text{Feed H}_2\text{O TDS}}$$

Water Production

PRODUCT WATER RATE

Usable water production from an RO system is designated **product water rate**, produced on a daily basis. The rate is normally described in gallons per day (gpd) or milliliters per minute (ml/min).

REJECT WATER RATE

The flow of water to drain is designated as **reject water rate**, as measured in gallons per day (gpd) or milliliters per minute (ml/min).

Using a graduated cylinder the formulas are:

Milliliters per minute x 0.38	= gallons per day
Ounces per minute x 11.2	= gallons per day

REJECT RATIO

The **reject ratio** is the amount of water produced compared to the amount of water flowing to drain.

The formula is as follows:

$$\text{Reject Ratio} = \frac{\text{Reject Rate}}{\text{Product Rate}}$$

Percent recovery

The **percent recovery** is another way to measure the amount of water produced compared to the amount of water which is actually used.

The formula to determine percent recovery is as follows:

$$\text{Percent Recovery} = \frac{\text{Product H}_2\text{O Rate} \times 100\%}{\text{Feed H}_2\text{O Rate}}$$

NOTE: Product water rate is the sum of the feed water flow rate and reject water flow rate.

For example:

Product water rate	= 10 gpd
Reject water rate	= 40 gpd
Feed water	= (10 gpd + 40 gpd) or 50 gpd
Percent Recovery	= 20%

Water Pressure and Temperature

Product water quality and production of RO systems is dependent on pressure and temperature. Typically, RO membranes are treated at standard conditions of 77°F (25°C) and 60 psi (4 bar) discharging to atmosphere. In general, the higher the pressure differential and temperature, the greater the quality and quantity of water produced. These factors should be considered when sizing RO systems for a particular application.

Installation Instructions

Residential Reverse Osmosis Drinking Water System

VI. FITTINGS INSTALLATION INSTRUCTIONS

This RO systems utilize Quick Connect fittings. These user-friendly fittings provide superior performance and may be provided with this system.

Quick Connect Fittings Installation Instructions

Step 1. Cut the tubing

Cut the tube cleanly and squarely. Ensure that the tube has a smooth outside diameter without any burrs, chamfers or score marks prior to inserting it into the fitting. Tubing that has not been cut properly can cause drips and leaks.

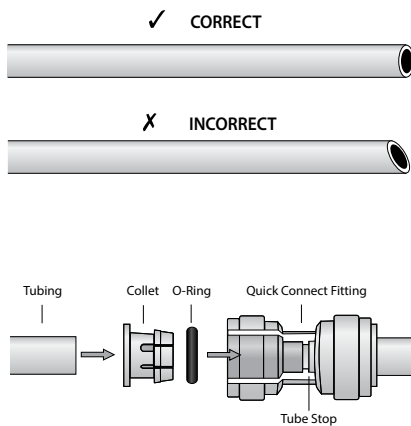

Step 2. Insert tubing

Push the tubing through the collet and o-rings until it bottoms out against the tube stop. The collet holds the tube in place and the o-ring provides a leak resistant seal. If you need to remove the tubing always re-cut before connecting tubing again. Scores on tubing can cause failure.

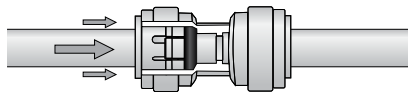

Step 3. Inspect and test

Push and pull the tubing toward and away from the fitting to ensure that it has been installed properly. Test and inspect the installation for any leaks.

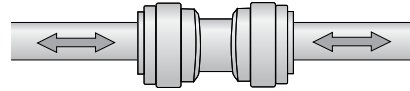

Quick Connect Fittings - Tube removal

Relieve pressure from the tubing and fitting. Push the collet flange against the fitting body while pulling the tubing away from the fitting to release it.

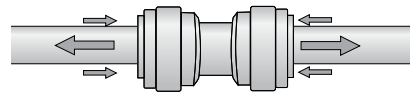

Conventional Compression fittings

If Quick Connect fittings are not used, it is essential to install inserts at the ends of all tube connections when conventional fittings are used.

- ⚠ **Should a leak occur at a fitting, the cause is generally defective tubing. To fix a leak, relieve pressure, release tubing, cut off at least 1/4" from the end (square cut), reattach the tubing and confirm the connection is leak free. Each time a new connection is made, it is advisable to cut off 1/4" from the end of the tubing using these fittings.**

VII. 4 STAGEREVERSE OSMOSIS SYSTEMS FLOW CHART

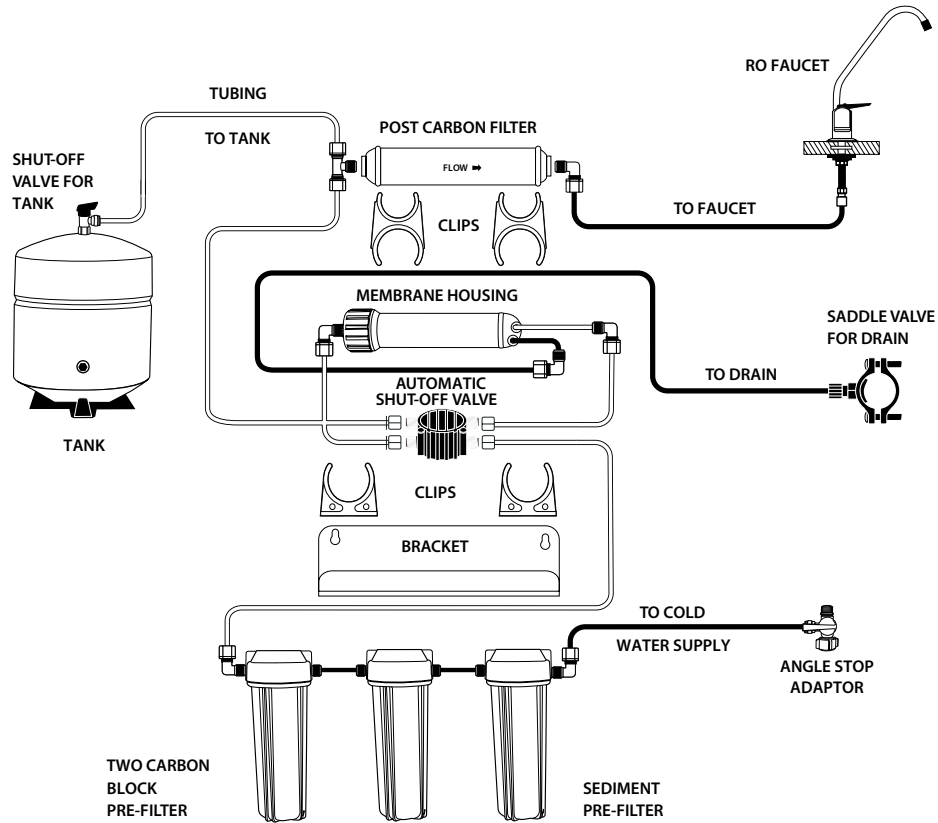

SPARE PARTS

PART NUMBER	DESCRIPTION	QTY
HF2-10WHWH14	Pursanova [OEM hydronix] NSF Slim Flat Cap Filter Housing 10" White Body, 1/4" White Flat Cap	3
SDC-25-1005	Pursanova [OEM hydronix] NSF Sediment Filter 2.5" x 9 7/8", 5 micron (Pre-filter Sediment)	1
CB-25-1005	Pursanova [OEM hydronix] NSF Carbon Block Filter 2.5" x 9 7/8", 5 micron (Pre-Filter Activated Carbon)	2
ICF-10Q	Pursanova [OEM] Inline Coconut Filter 2000 Gal, 2" x 10", 1/4" Quick Connect (Post filter Carbon)	1
LF-LR-STND	Pursanova [OEM hydronix] Long Reach 3" Shank, Chrome Plated (no air gap)	1
RO-4.5-W14	NSF 4.5 Gallon White Tank 1/4" NPT Stainless Steel	1
DS-14QC	Drain Saddle 1/4" Quick Connect, Black	1
ASV-14QW	Auto Shut-off Valve 1/4" Quick Connect, White	1
FM-60W	Bracket White Triple Housing, Bend Up for HF2 Housing	1
CLP-25W	Membrane Housing Clip 2.5", White	2
CLP-2520W	Double Clip 2.5" x 2", White	2
MH03-1812WH	NSF 1.8" x 12" Membrane Housing White	1
TW-1812-50	NSF TFC 50 GPD Membrane Dry (R/O Membrane)	1
HDF-ASVA-14	NSF Angle Stop Adaptor 3/8" Thread x 1/4" Tube (with 1/2" Adaptors)	1
HDF-FE0402	NSF 1/4" Tube x 1/8" FNPT, Fixed Elbow	2
HDF-FE0404	NSF 1/4" Tube x 1/4" FNPT, Fixed Elbow	2
HDF-ECV0402	NSF 1/4" Tube x 1/8" MNPT, Elbow Check Valve	1
HDF-BVT0404	NSF 1/4" Tube x 1/4" FNPT, Female Tank Ball Valve	1

VIII. FILTER REPLACEMENT INSTRUCTIONS

1. Turn off water supply to filter.
2. Depress release button (if present) to relieve pressure in filter housing.
3. Unscrew housing using filter wrench.

NOTE: When opening filter housing to change cartridge, it is common for O-ring/Gasket to lift out of housing and stick to cap.

4. Remove used cartridge and discard. Rinse out housing and fill about 1/3 full with water. Add about 2 to 3 tablespoons of bleach and scrub thoroughly with brush or sponge. Rinse thoroughly.
5. Remove O-ring/Gasket from sump and wipe groove and O-ring/Gasket clean. Lubricate O-ring/Gasket with a coating of clean silicone grease. Place O-ring/Gasket back in place and press O-ring down into the groove.

NOTE: This step is important to ensure proper filter seal. Make sure the O-ring is seated level in the groove (or gasket is on rim of sump).

CAUTION: If O-ring/Gasket appears damaged or crimped it should be replaced at this time. See your local dealer for replacements parts.

6. Insert a new cartridge into the sump making sure that it slips down over the sump standpipe.
7. Screw the sump onto the cap and hand tighten. **DO NOT OVER-TIGHTEN.** Make sure cartridge slips over the cap standpipe.
8. Turn on the water supply slowly to allow housing to fill with water.
9. Depress the pressure release button (if present) to release trapped air from filter.
10. Check for leaks before leaving installation.

IX. WARNINGS

⚠ DO NOT USE with water that is microbiologically unsafe or of unknown quality without adequate disinfection before or after the unit.

NOTE: Activated carbon cartridges and carbon block cartridges may contain a small amount of carbon fines (very fine black powder) and a new cartridge, after installation, should be flushed with sufficient water to remove the fines before using the water.

Each time you use water from your filtered water tap for drinking or cooking purpose, it is recommended that you run (flush) the tap at least 10 seconds prior to using water. This is particularly important if the water tap is not used daily.

NOTE: Certain types of harmless bacteria will attack cellulose material. Cartridge containing cellulose may seem to disintegrate, produce a "musty" odor, or form a black precipitate due to the bacteria. If you notice any of the above problems while

using the cellulose media cartridges, switch to a synthetic media cartridge or consult the manufacturer.

NOTE: Replacement cartridges have a limited service life. Changes in taste, color and flow of the water being filtered are signals that replacement of the cartridge is or soon may be necessary.

⚠ CAUTION: Filter housing must be protected against freezing and extreme temperatures.

Filter housings should not be in direct contact with sunlight or solvents or cleaning fluids that emit chemical vapor fumes for a prolonged period of time since it can make housings brittle and cause damage to the systems plastic parts which could lead to failure. Pressure should **always be measured before installation** and water pressure regulators should be installed or corrected in the main line or in front of the housing if water pressure exceeds manufacturers' maximum water pressure: 75 PSI. Installers should make sure filters and replacement filters are the correct length and are not too long so as to not cause undo strain and stress on the housing. A leak detector **must be installed** on all installations where high pressure, water hammer and pressure spikes are known or suspected to be present and on all installations where pressure is over 60 PSI. Failure to the above may result in cracking of the filter housing, water leakage and water damage.

⚠ CAUTION: All filtration systems contain other parts that have a limited service life.

Exhaustion of the service life of those parts often cannot be easily detected. Commonly, it is only after leakage has been observed or water damage has occurred that one is made aware that the service life has been exhausted. Inspect the filtration system regularly and replace parts that are questionable and/or show sign of wear.

⚠ IMPORTANT NOTICE: TO PREVENT COSTLY REPAIRS OR POSSIBLE WATER DAMAGE ALL CLEAR PLASTIC HOUSINGS MUST BE REPLACED EVERY 5 YEARS, AND EVERY 4 YEARS FOR OPAQUE HOUSINGS. IF YOUR HOUSING HAS BEEN IN USE FOR MORE THAN THE RECOMMENDED PERIOD, IT SHOULD BE REPLACED IMMEDIATELY. BE SURE TO DATE ANY NEW OR REPLACEMENT HOUSINGS FOR FUTURE REFERENCE AND INDICATE THE NEXT RECOMMENDED REPLACEMENT DATE.

X. WARRANTY

Limited three (3) year warranty for material defects only. Warranty is limited to repair or replacement of product only. Any misuse, mis-installation, lack of maintenance, exceeding maximum pressure or failure to follow these instructions will void limited warranty.